

DIN-Power H015FTC1-1

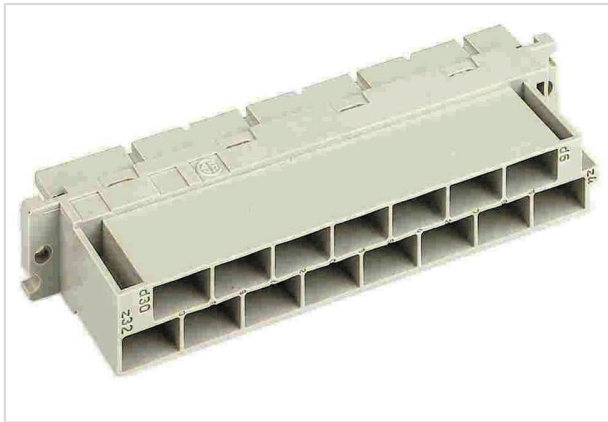

Image is for illustration purposes only. Please refer to product description.

Part number	09 06 215 2871
Specification	DIN-Power H015FTC1-1
HARTING eCatalogue	https://b2b.harting.com/09062152871

Identification

Category	Connectors
Series	DIN 41612
Identification	Type H15
Element	Female connector
Description of the contact	Straight
Features	lead-free

Version

Termination method	Faston termination
Connection type	PCB to cable Cable to cable
Number of contacts	15
Contact configuration	Row d, positions 6, 10, ... , 26, 30 and row z, positions 4, 8, ... , 28, 32
Coding	Shroud coding
PCB fixing	With fixing flange

Technical characteristics

Contact spacing (mating side)	6.5 mm 10.16 mm
Rated current	15 A
Rated current	Rated current measured at 20 °C, see derating curve for details
Clearance distance	≥4.5 mm
Creepage distance	≥8 mm
Insulation resistance	>10 ¹² Ω



Pushing Performance
Since 1945

Technical characteristics

Contact resistance	≤8 mΩ
Limiting temperature	-55 ... +125 °C
Insertion and withdrawal force	≤90 N
Performance level	1 acc. to IEC 60603-2
Mating cycles	≥500
Test voltage $U_{r.m.s.}$	3.1 kV (contact-contact) 3.1 kV (contact-ground)
Isolation group	IIIa (175 ≤ CTI < 400)
Hot plugging	No

Material properties

Material (insert)	Thermoplastic resin, glass-fibre filled
Colour (insert)	RAL 7032 (pebble grey)
Material (contacts)	Copper alloy
Surface (contacts)	Silver plated Mating side
Material flammability class acc. to UL 94	V-0
RoHS	compliant
ELV status	compliant
China RoHS	e
REACH Annex XVII substances	Not contained
REACH ANNEX XIV substances	Not contained
REACH SVHC substances	Not contained
California Proposition 65 substances	Yes
California Proposition 65 substances	Antimony trioxide
Requirement set with Hazard Levels	R26

Specifications and approvals

Specifications	IEC 60603-2
UL / CSA	UL 1977 ECBT2.E102079 CSA-C22.2 No. 182.3 ECBT8.E102079
Railway classification	F4/I3 acc. to NFF 16-101/102

Commercial data

Packaging size	20
----------------	----



Pushing Performance
Since 1945

Commercial data

Net weight	43 g
Country of origin	Germany
European customs tariff number	85366990
GTIN	5713140012837
eCl@ss	27460201 PCB connector (board connector)

Current carrying capacity

The current carrying capacity of the connectors is limited by the thermal load capability of the contact element material including the connections and the insulating parts. The derating curve is therefore valid for currents which flow constantly (non-intermittent) through each contact element of the connector evenly, without exceeding the allowed maximum temperature.

Measuring and testing techniques acc. to IEC 60512-5-2

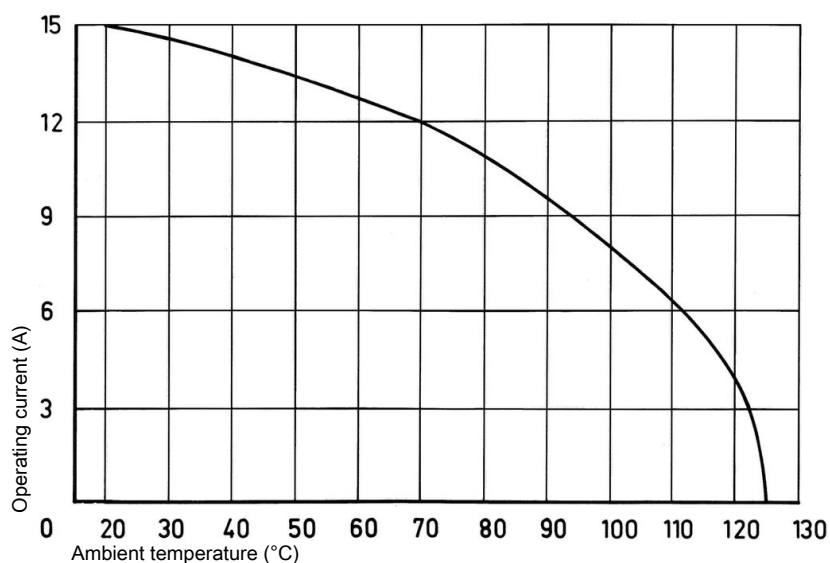

Shroud coding
(without loss of contact)

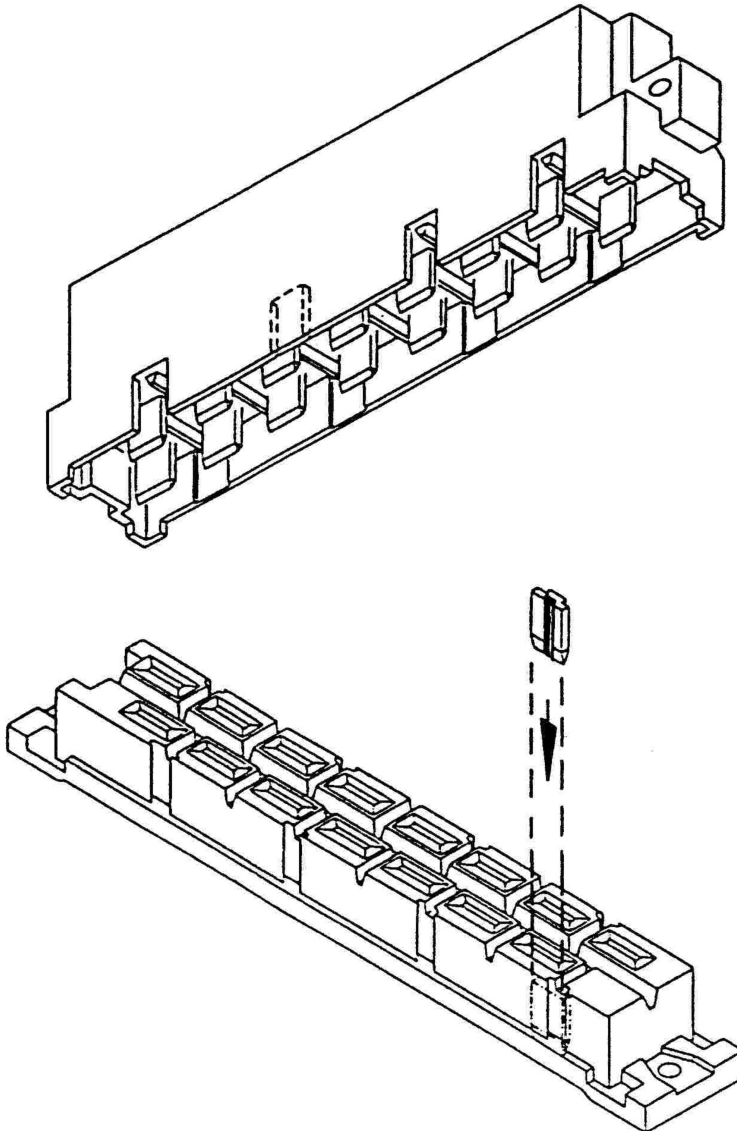

To avoid cross-plugging of adjacent connectors a coding system is required. Insert the code key 09 06 001 9918 into one of the keyways of the female connector as shown in the drawing. Break out the corresponding area of the male shroud. Connectors coded this way can only be applied in a minimum rack spacing of 20.32 mm.

Low currents and voltages

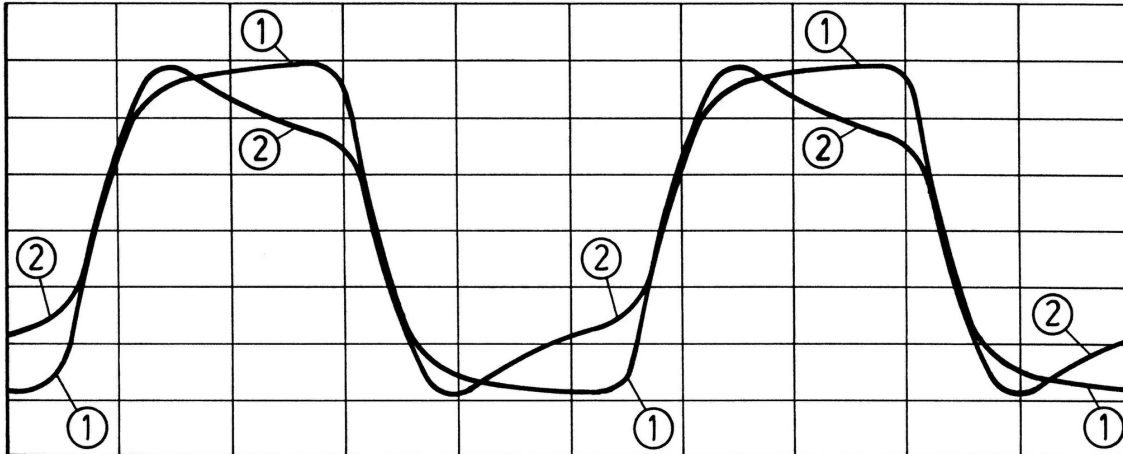

Changes to the transmitted signal after artificial ageing

- ① new contact
- ② after ageing

Type H standard contacts have a silver plated surface. This precious metal has excellent conductive properties. In the course of a contact's lifetime, the silver surface generates a black oxide layer due to its affinity to sulphur. This layer is smooth and very thin and is partly interrupted when the contacts are mated and unmated, thus guaranteeing very low contact resistances. In the case of very low currents or voltages small changes to the transmitted signal may be encountered. This is illustrated above where an artificially aged contact representing a twenty year life is compared with a new contact.

In systems where such a change to the transmitted signal could lead to faulty functions and also in extremely aggressive environments, HARTING recommend the use of gold plated contacts.

Below is a table derived from actual experiences.

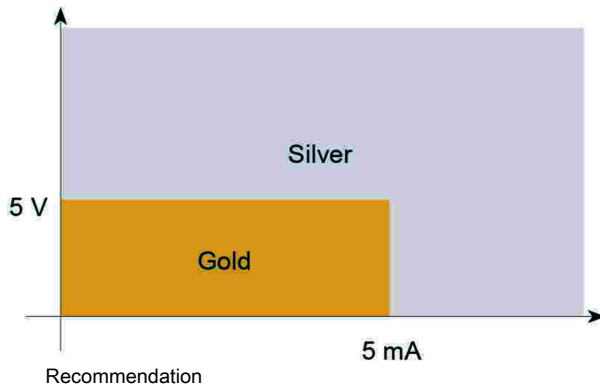

Mating conditions

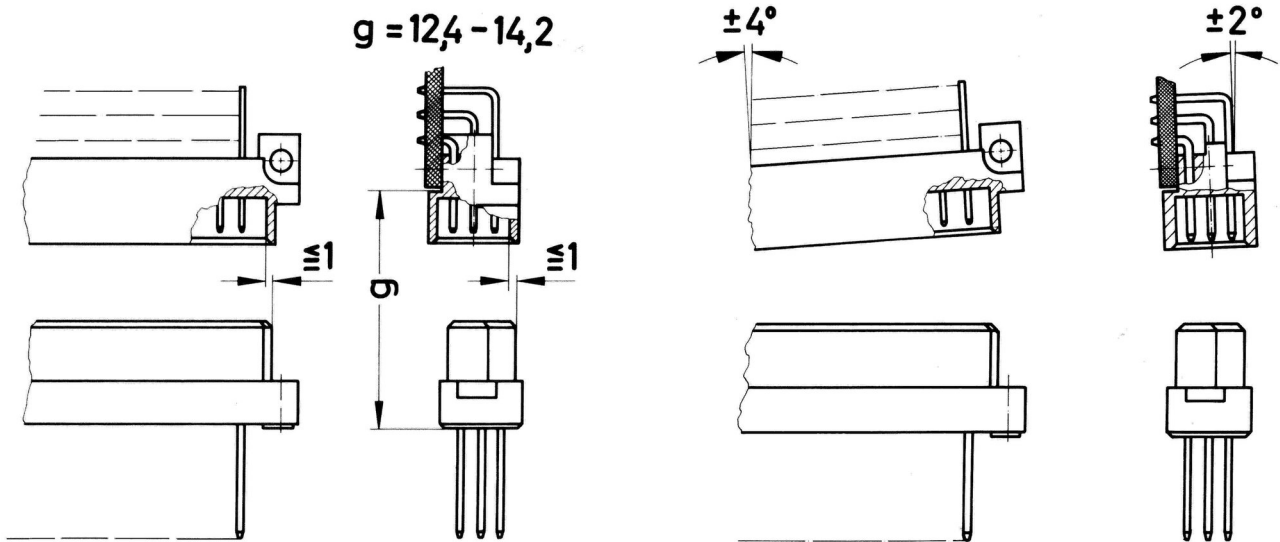

To ensure reliable connections and prevent unnecessary damage, please refer to the application data diagrams. These recommendations are set out in IEC 60603-2. The connectors should not be coupled and decoupled under electrical load.