

D-Sub M 2W2C ANG MA 20A UNC NM30 BL

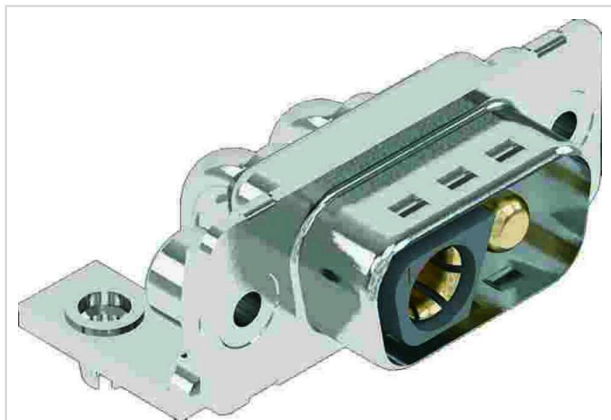

Image is for illustration purposes only. Please refer to product description.

Part number	09 69 100 9084
Specification	D-Sub M 2W2C ANG MA 20A UNC NM30 BL
HARTING eCatalogue	https://b2b.harting.com/09691009084

Identification

Category	Connectors
Series	D-Sub
Identification	Mixed
Element	Connector
Description of the contact	Turned Angled

Version

Termination method	Wave soldering termination
Gender	Male
Size	D-Sub 1
Number of contacts	2
Number of signal contacts	0
Number of power contacts	2
Coding	With coding
PCB fixing	With frame With board locks
Locking type	Fixing flange with thread 4-40 UNC

Technical characteristics

Flange height	7.3 mm
Rated current (power)	20 A
Insulation resistance	$>10^5 \Omega$
Contact resistance, power area	$\leq 1 \text{ m}\Omega$



Pushing Performance
 Since 1945

Technical characteristics

Tightening torque	≤0.6 Nm Female screw lock
Limiting temperature	-55 ... +125 °C
Performance level	NM 30 (S4) 1
Mating cycles	≥500
Test voltage $U_{r.m.s.}$	1 kV
Isolation group	IIIa ($175 \leq CTI < 400$)
PCB thickness	1.6 mm
Hot plugging	No

Material properties

Material (insert)	Thermoplastic resin, glass-fibre filled (PBT) Shell: steel, tin plated
Colour (insert)	Black
Material (contacts)	Copper alloy
Surface (contacts)	Gold plated Mating side Sn over Ni Termination side
Layer thickness	≥0.76 µm
Layer thickness	≥30 µinch
Material flammability class acc. to UL 94	V-0
RoHS	compliant with exemption
RoHS exemptions	6(a) / 6(a)-I: Lead as an alloying element in steel for machining purposes and in galvanised steel containing up to 0,35 % lead by weight / Lead as an alloying element in steel for machining purposes containing up to 0,35 % lead by weight and in batch hot dip galvanised steel components containing up to 0,2 % lead by weight 6(c): Copper alloy containing up to 4 % lead by weight
ELV status	compliant with exemption
China RoHS	50
REACH Annex XVII substances	Not contained
REACH ANNEX XIV substances	Not contained
REACH SVHC substances	Yes
REACH SVHC substances	Lead
ECHA SCIP number	ecef7555-f643-4ceb-a337-fc54762297f1
California Proposition 65 substances	Yes
California Proposition 65 substances	Lead



Pushing Performance
Since 1945

Material properties

Requirement set with Hazard Levels	R26
------------------------------------	-----

Specifications and approvals

Specifications	DIN 41652-1 CECC 75301-802
UL / CSA	UL 1977 ECBT2.E102079

Commercial data

Packaging size	50
Net weight	14.6 g
Country of origin	Germany
European customs tariff number	85366990
GTIN	5713140096295
eCl@ss	27440214 D-Sub coupler